

# Inlet Metering Valve

## Corrosion Resistant

### BENEFITS

Corrosion resistant

Excellent resistance against debris

Fast response control

Durable and reliable

Validated on high-pressure DCR pumps



**Wide Application Range**



**Flexible Design**



**Low Emissions**

*An Inlet Metering Valve (IMV) for diesel common rail pumps to address applications where corrosion and dirty fuel can significantly reduce the life of the valve and the pump. The IMV's design uses high-quality corrosion-resistant components and proprietary features to prevent large debris from entering the valve, thus providing exceptional robustness to corrosion and debris, resulting in long life and durability in harsh environmental conditions.*

# TECHNICAL SPECS

FEATURE	SPECIFICATION
Operating Pressure	Up to 15 bar
Flow [2 bar ΔP]	5.5 L/min
Supply Voltage	10.5 - 24 V
Interface	Customizable
PWM frequency	180 Hz, 250 Hz, 400 Hz
Leakage in fully close position	0.08 L/h

# UNIQUE FEATURES

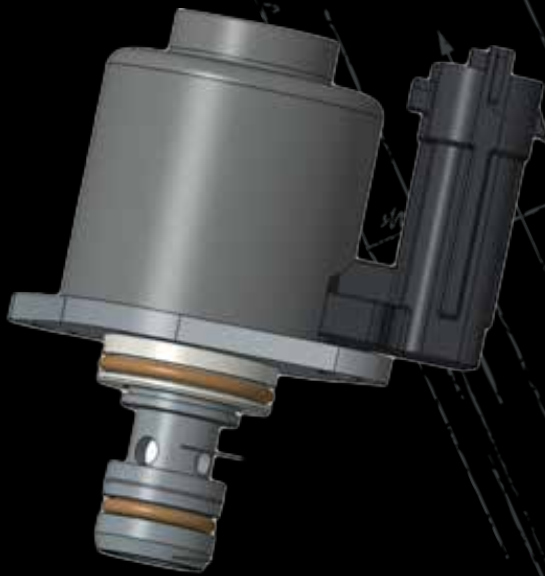

## NEW CONNECTOR

- Flexible design with customizable connector orientation and type

## CORROSION-RESISTANT FILTER

- High-quality corrosion-resistant components and proprietary features prevent large debris from entering the valve
- Built-in filter
- Lower flow hysteresis

## CUSTOMIZABLE DESIGN

- Quick customization of both mechanical and electrical interfaces
- Direct replacement for both diesel engine service and aftermarket

PATENT PENDING